

SILICON BRIDGE RECTIFIER

REVERSE VOLTAGE : 50 --- 1000 V CURRENT: 1.0A

FEATURES

- Plastic package has Underwriters Laboratory Flammability Classification 94V-0
- Glass passivated chip junction
- Rating to 1000V PRV
- Ldeal for printed circuit board
- High temperature soldering guaranteed :260 C/10s seconds at terminals
- Component in accordance to ROHS 2002/95/EC and WEEE2002/96/EC

MECHANICAL DATA

- Case:DB molded plastic body
- Epoxy:UL94V-0 rate flame retardant
- Terminals:Plated leads solderable per MIL-STD-750,method 2026
- Mounting position:Any
- Weight:0.02ounce,0.38 gram

DB-1

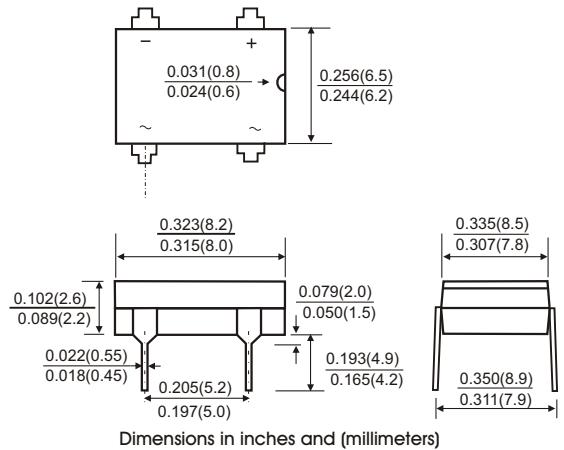

MAXIMUM RATINGS AND CHARACTERISTICS

@ 25°C Ambient Temperature (unless otherwise noted)

Single phase,half wave,60 Hz,resistive or inductive load. For capacitive load,derate by 20%.

		Symbols	DB101	DB102	DB103	DB104	DB105	DB106	DB107	Units
Maximum Recurrent Peak Reverse Voltage		V_{RRM}	50	100	200	400	600	800	1000	Volts
Maximum RMS Voltage		V_{RMS}	35	70	140	280	420	560	700	Volts
Maximum DC Blocking Voltage		V_{DC}	50	100	200	400	600	800	1000	Volts
Maximum Average Forward Rectified Current		$I(AV)$	1.0							Amp
Peak Forward Surge Current 8.3ms single half sine-wave superimposed on rated load (JEDEC method)		I_{FSM}	50							Amps
Maximum Instantaneous Forward Voltage at 1.0 A DC		V_F	1.1							Volts
Maximum DC Reverse Current at rated DC blocking voltage	$T_A=25^\circ C$	I_R	10							μA
	$T_A=125^\circ C$		500							
Typical junction capacitance(Note 1)		C_J	25							pF
Typical thermal resistance(Note 2)		$R_{\theta JA}$	40							K/W
Operating junction and storage temperature range		T_J T_{STG}	-55 to +150							$^\circ C$



RATINGS AND CHARACTERISTIC CURVES

FIG.1-TYPICAL FORWARD CURRENT DERATING CURVE

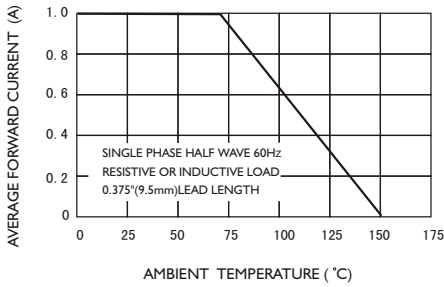

FIG.2-MAXIMUM NON-REPETITIVE FORWARD SURGE CURRENT

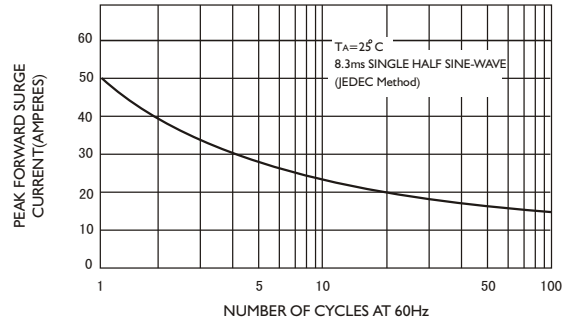

FIG.3-TYPICAL JUNCTION CAPACITANCE

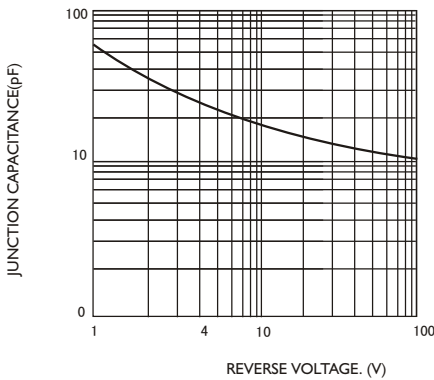

FIG.4-TYPICAL FORWARD CHARACTERISTICS

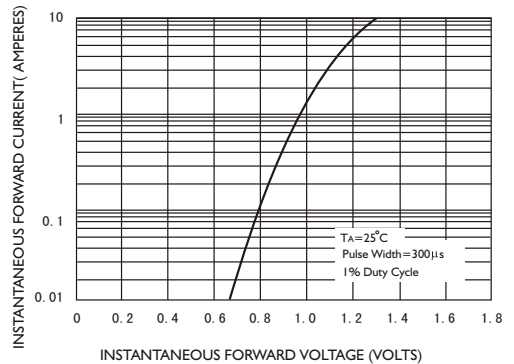

FIG.5-TYPICAL REVERSE CHARACTERISTICS

