

## TO-92 Plastic-Encapsulate Transistors

### Features

- General purpose switching and amplification
- NPN Transistors

### MECHANICAL DATA

- Case style:TO-92 molded plastic
- Mounting position:any

### TO-92

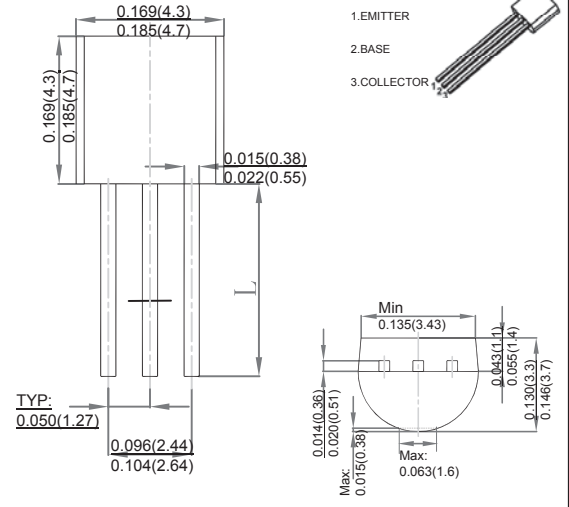

## MAXIMUM RATINGS AND CHARACTERISTICS

@ 25°C Ambient Temperature (unless otherwise noted)

Parameter	Symbol	Rating	Unit
Collector-base voltage	$V_{CB0}$	60	V
Collector-emitter voltage	$V_{CEO}$	30	V
Emitter-base voltage	$V_{EBO}$	5	V
Collector current-continuous	$I_C$	0.6	A
Collector Power Dissipation	$P_C$	625	mW
Thermal Resistance From Junction To Ambient	$R_{\theta JA}$	200	$^{\circ}C/W$
Junction temperature	$T_J$	150	$^{\circ}C$
Storage temperature	$T_{stg}$	-55 to +150	$^{\circ}C$

Parameter	Symbol	Testconditions	Min	Typ	Max	Unit
Collector-base breakdown voltage	$V_{(BR)CB0}$	$I_C = 0.01mA, I_E = 0$	60			V
Collector-emitter breakdown voltage	$V_{(BR)CEO}$	$I_C = 10mA, I_B = 0$	30			V
Emitter-base breakdown voltage	$V_{(BR)EBO}$	$I_E = 10\mu A, I_C = 0$	5			V
Collector cutoff current	$I_{CBO}$	$V_{CB} = 500V, I_E = 0$			0.01	$\mu A$
Emitter cutoff current	$I_{EBO}$	$V_{EB} = 4.0V, I_C = 0$			0.1	$\mu A$
DC current gain	$h_{FE}$	$I_C = 1.0mA, V_{CE} = 10V$	100		300	
		$I_C = 0.1mA, V_{CE} = 10V$	35			
		$I_C = 500mA, V_{CE} = 10V$	30			
Collector-emitter saturation voltage	$V_{CE(sat)}$	$I_C = 500mA, I_B = 50mA$			1.0	V
Base-emitter saturation voltage *	$V_{BE(sat)}$	$I_C = 500mA, I_B = 50mA$			2.0	V
		$I_C = 50mA, I_B = 5mA$			1.0	
Transistor frequency	$f_r$	$V_{CE} = 20V, I_C = 20mA, f = 100MHz$	250			MHz
Collector output capacitance	$C_{ob}$	$V_{CB} = 10V, I_E = 0, f = 100MHz$			8	pF
Delay time	$T_d$	$V_{CC} = 30V, V_{BE} = -0.5V$			10	ns
Rise time	$T_r$	$I_C = 150mA, I_{B1} = 15mA$			25	ns
Storage time	$T_s$	$V_{CC} = 30V, I_C = 150mA$			225	ns
Fall time	$T_f$	$I_{B1} = I_{B2} = 15mA$			60	ns

\* Pulse Test: Pulse Width  $\leq 300\mu s$ , Duty Cycle  $\leq 2.0\%$ .